

MM1500i - Flange Facer **12 - 60" (305 - 1500mm)**

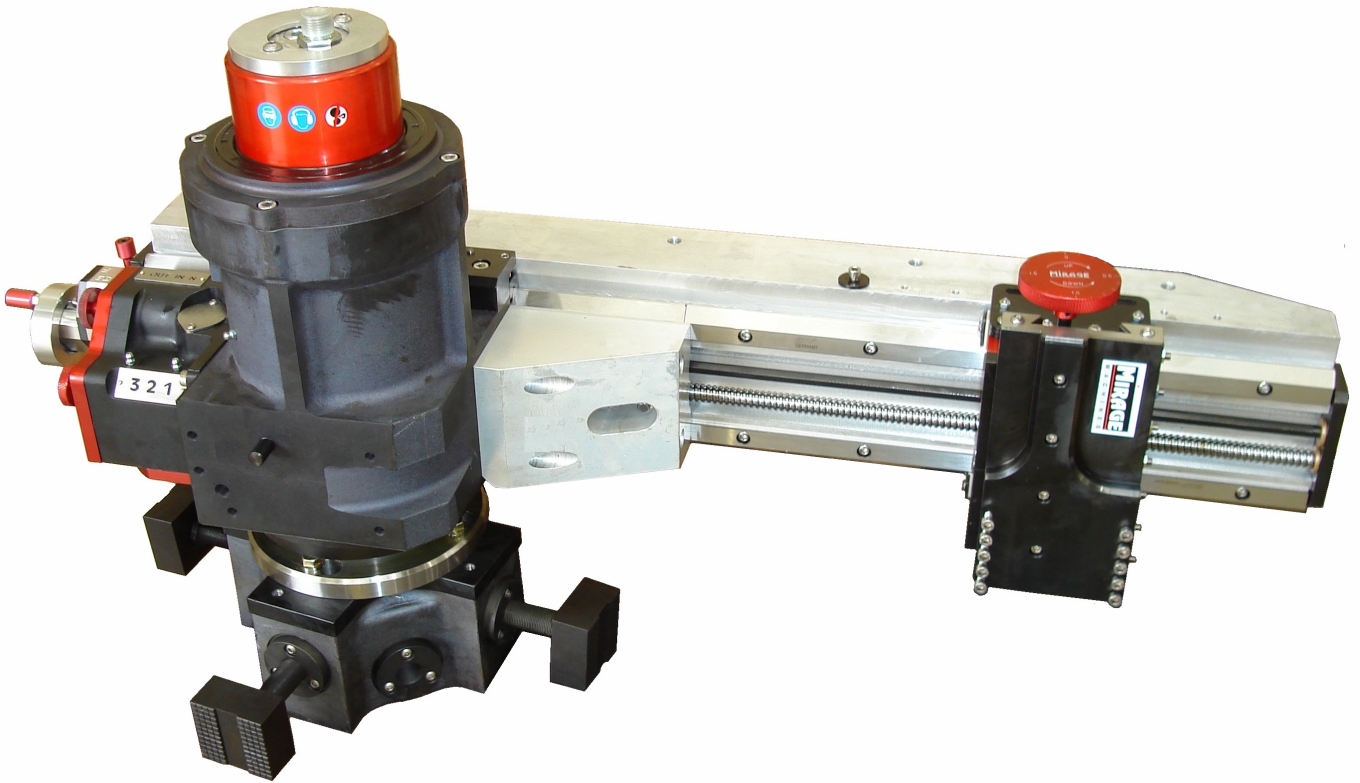

An internally mounted flange facing machine for all types of flange facing, seal groove machining, weld preparation and counter boring

- ***Latest linear technology***
- ***3 continuous groove facing feeds***
- ***Swivel powered tool post***
- ***Low noise level 80dB drive***
- ***Quick set adjustable jaws***

Technical Details

RANGE		
Minimum Facing diameter	305mm	12"
Maximum Facing diameter	1525mm	60"
Minimum Clamping diameter	290mm	11.4"
Maximum Clamping diameter	1400mm	55"
Tool post travel	102mm	4"
R.P.M	Min: 5	Max: 22
Drive – Pneumatic @ 90 p.s.i (6 bar)	4.0 Hp	3.0 Kw
Air Consumption / supply required	98 s.c.f.m	2.69 m3/m

FEED RATES		
Facing Feed rates (3 off in / out)	0.20 -0.32 - 0.81mm	0.008 – 0.012 - 0.032"
Boring feed rates (3 off up / down)	0.05 – 0.10 - 0.20mm	0.002 -0.004 - 0.008"

WEIGHTS AND DIMENSIONS		
Machine weight including arm (not base)	412 kgs	906 lbs
Shipping weight	490 Kgs	1078 lbs

Shipping dimensions	L – 123cm - (48")	W- 82cm (32")	H- 83cm (33")
---------------------	-------------------	---------------	---------------

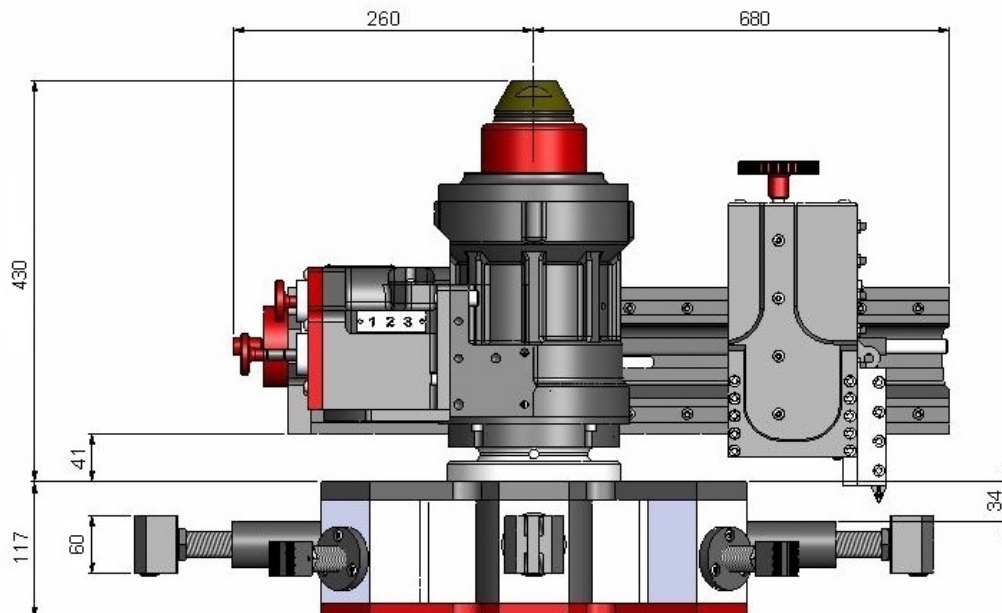

The machine is supplied complete with toolkit including tools and inserts, air filter lubricator and hose connection, all required mounting bases and extensions, storage / shipping box, CE certificate, Packing list and Manual

10 Enterprise Way, Jubilee Parkway. DERBY DE21 4BB. UK

Tel: +44 (0)1332 291767 Fax: +44 (0)1332 370356

Email: sales@miragemachines.com www.miragemachines.com