

BLG1000 Belt Grinding machine

40" stroke – Ø1m – 5m capacity



A heavy duty belt grinding machine to machine large rollers with heavy duty belt grinding head and optional belt grit for heavy metal removal or fine polishing.

- ***High metal removal belt grinding head***
- ***Precision linear slide – 1m stroke***
- ***Out of round compensating rollers***
- ***Fast mount magnets (optional)***
- ***Auto cross feed (optional)***

Technical Details

RANGE		
Minimum diameter	1000mm	40"
Maximum diameter	5000mm	198"
Spindle travel (in feed)	300mm	12"
Spindle R.P.M	Min: 200	Max: 2000
Main axis stroke	1000mm	40"
Linear track available max. stroke	4000mm	157"
Belt Drive – Hydraulic (weight + 6 kgs)	3.73Kw	5.0 Hp
Air supply (compensating rollers)	0.8m3	28 scfm
Hydraulic supply required @ 1050 p.s.i	40 L/min	9 gal/min

FEED RATES		
Linear or feed rate (auto)	0 - 65mm/min	0 - 2.5"/min
Feed rate – Manual / revolution hand feed	5mm/rev	0.197"/rev

WEIGHTS AND DIMENSIONS			
Machine weight	230 kgs	506 lbs	
Shipping weight	280 Kgs	616 lbs	
Shipping dimensions	L - 120cm - (47")	W- 40cm (16")	H- 40cm (16")

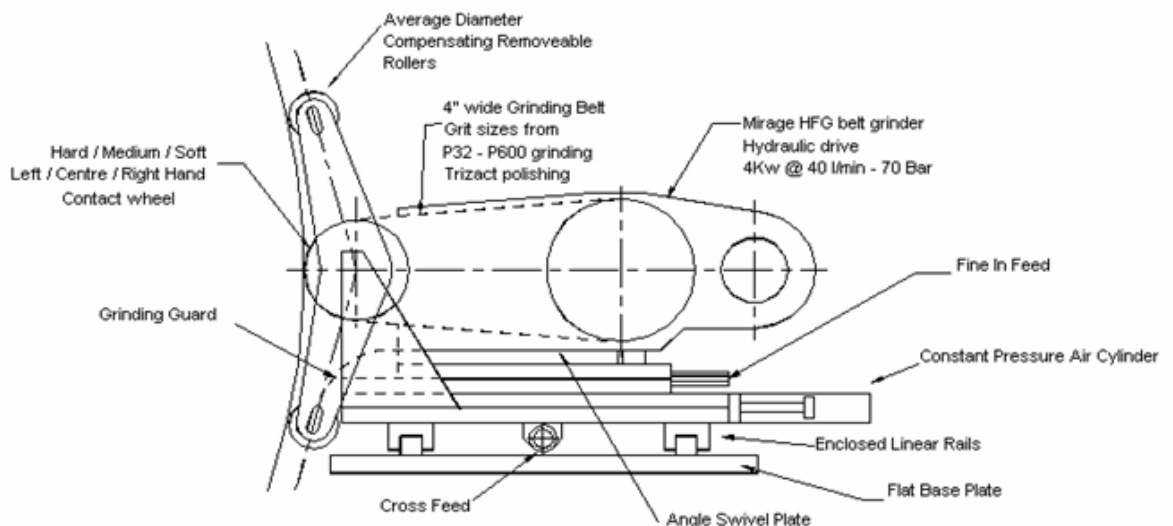

The machine is supplied complete with toolkit, air filter lubricator (when required) and hose connection, 1 off 60 grit band, 1 off 240 grit band, storage / shipping box, CE certificate, Packing list and Manual

10 Enterprise Way, Jubilee Parkway. DERBY DE21 4BB. UK

Tel: +44 (0)1332 291767 Fax: +44 (0)1332 370356

Email: sales@miragemachines.com www.miragemachines.com