

HT50 Portable drill

17" stroke – Ø5" capacity

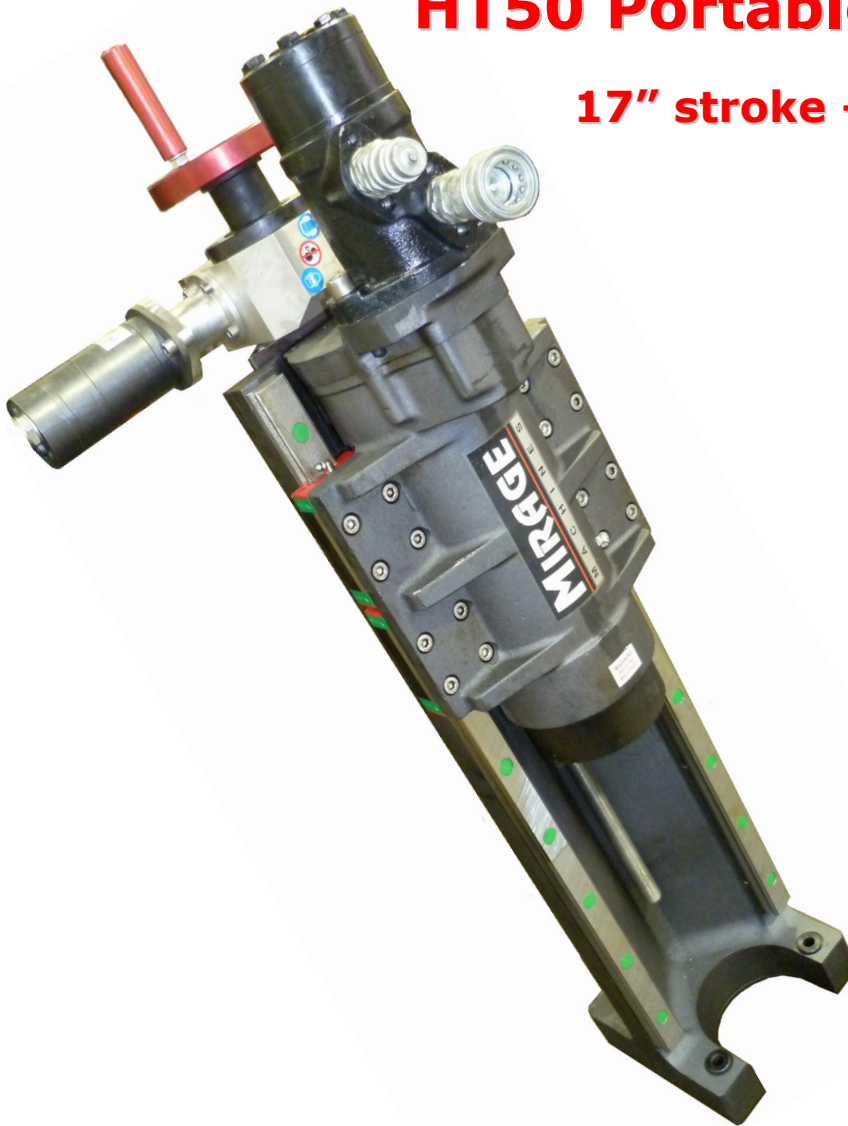

A versatile portable drilling and boring machine for general drilling and stud removal applications. The machine can be bolted directly to the work piece or have our new optional switch magnet base.

- ***Linear rails & guides – accuracy and rigidity***
- ***ISO50 spindle accepts standard tooling***
- ***Geared reduction spindle drive***
- ***Auto feed / Hand feed gearbox and motor***

Technical Details

RANGE		
Maximum Hole diameter (through base)	125mm	5"
Standard stroke	405mm	16"
Maximum stroke available (optional)	800mm	31.5"
R.P.M – standard	Min: 5	Max: 60
Drive – Pneumatic @ 6 bar (90 p.s.i)	4.0 Hp	3.0 Kw
Drive – Hydraulic @ 70 bar (1050 p.s.i)	5.0 Hp	3.7 Kw
Feed – Pneumatic @ 6 bar (90 p.s.i)	1.5 Hp	1.11 Kw
Feed – hydraulic @ 70 bar (1050 p.s.i)	2.2 Hp	1.64 Kw
Air consumption required	98 s.c.f.m	2.69 m3/m
Hydraulic supply required	50 L/min	13 gal/min

FEED RATES		
Hand feed (Feed / revolution)	2.5mm	0.100"
Variable auto feed (optional)	0 – 32 mm/min	0 - 1.25"/min

WEIGHTS AND DIMENSIONS		
Machine weight (including 10kg auto feed)	98 kgs	216 lbs
Shipping weight	127 Kgs	279 lbs

Shipping dimensions	L - 110cm - (43")	W- 40cm (16")	H- 49cm (19")
---------------------	-------------------	---------------	---------------

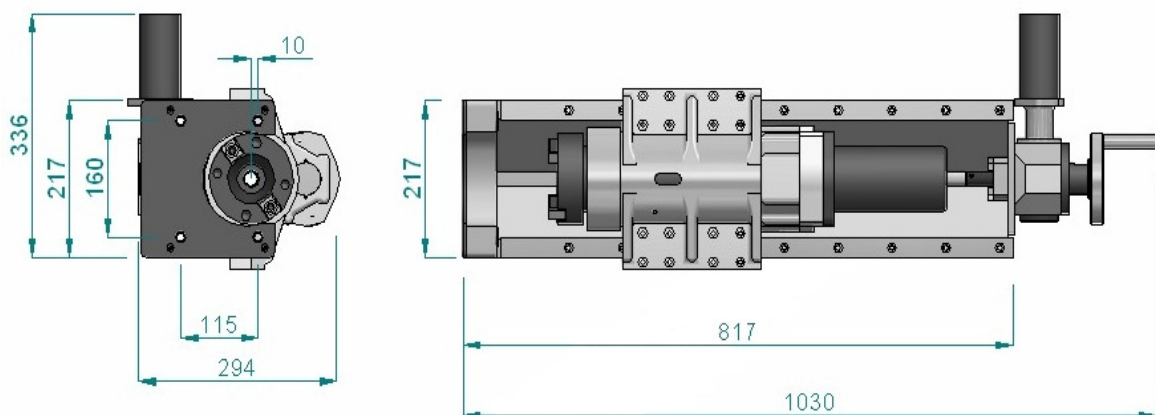

The machine is supplied complete with toolkit, air filter lubricator (when air driven) and hose connection, storage / shipping box, CE certificate, Packing list and Manual